



Five Star Precision Components

www.fstooling.com
www.fstooling.net

Date:2018.12.06



Category



- 01 **About us**
Our Company Profile
- 02 **Company Tour**
Our Equipment
- 03 **Our Products**
Our Professions and Skills
- 04 **Our Clients**
Direct and Indirect Customers



About us

Our Company Profile

Welcome to visit our website at :
www.fstooling.com or www.fstooling.net

Started from **2015**

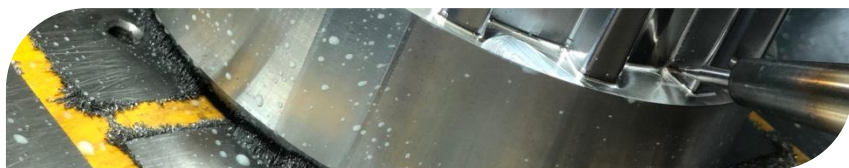
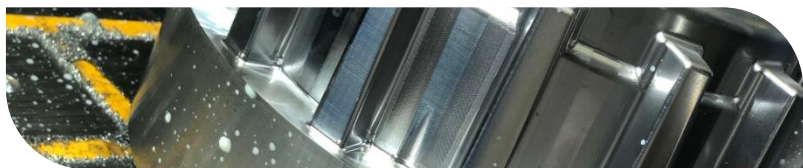

- Located in Dongguan, China. We specialize in manufacturing of precision metal components and custom mould components such as **Sliders, Lifters/Cams, Inserts.**

- With state-of-the-art **DMG 5-axis CNC, Charmilles precision EDM, Charmilles wire-cut** as well automatically Hexagon CMM, we can keep part's tolerance with +/- 0.005mm (0.0002"). We manufactured lots of components for TYCO indirectly each year. Our other strong point is to produce custom components for plastic injection mold or die-casting mold promptly. As we have skillful and dedicated members, good machines and client-oriented management.

Our Mission

What We Aim to Do



Five-Star

We Share:

not only the tasks, challenges and difficulties, but also **dreams, happiness, success and benefits.**



We Care to:

make sure our customers are **100% happy** with our products' **quality, lead time** as well **our services.**

We Devoted to

our professions and skills with **constant personnel training and mature system management.**

Our Team

Part of Our Structure



◆ Five-Star(DG)

Program Team, QC staffs and HR.



◆ Management Team

Each has his own profession while work together as a whole.



◆ Engineering Team(SZ)

Served as a representative of our customers, directly responsible to the customers and our bosses.



◆ Program Team

Professional program engineers.





Company Tour

Our Equipment

Welcome to visit our website at :
www.fstooling.com or www.fstooling.net



●CNC

●DMG 5 axis machine

●Graphite Machines

●CNC



●Water Grinder



●Grinding Machines



● AgieCharmilles FORM E 350



● AgieCharmilles SP3



● AgieCharmilles CUT C 350



●Projector



●Hexagon CMM

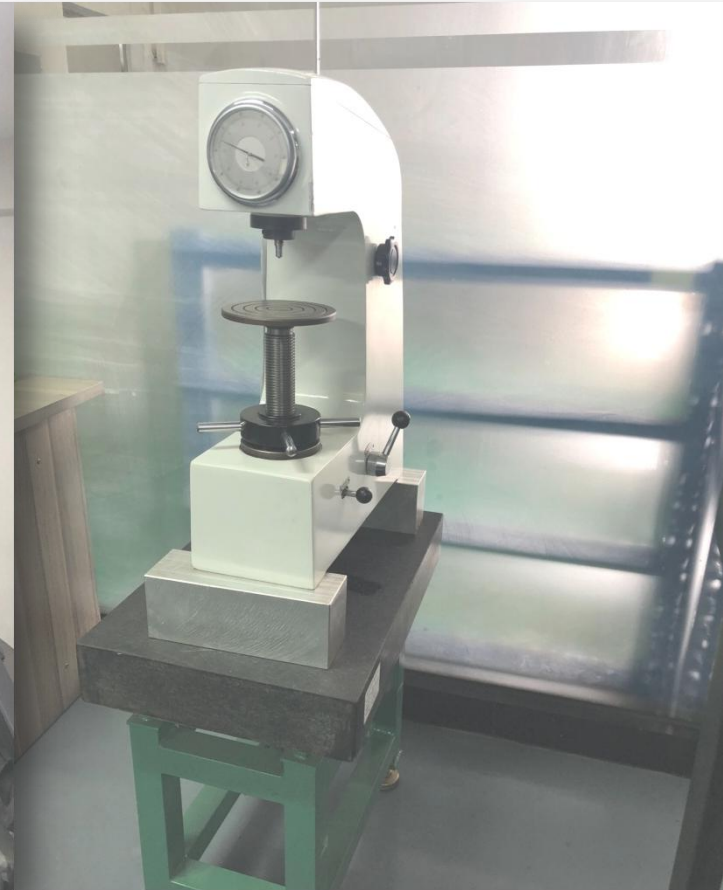

●Hardness Inspector



Our Products

Our Professions and Skills

Welcome to visit our website at :
www.fstooling.com or www.fstooling.net



Our Products

What We Can Do



Five-Star



- Core and Cavity

We make custom mold components, especially those parts that need CNC, EDM, WC processing.



Our Products

What We Can Do



Five-Star

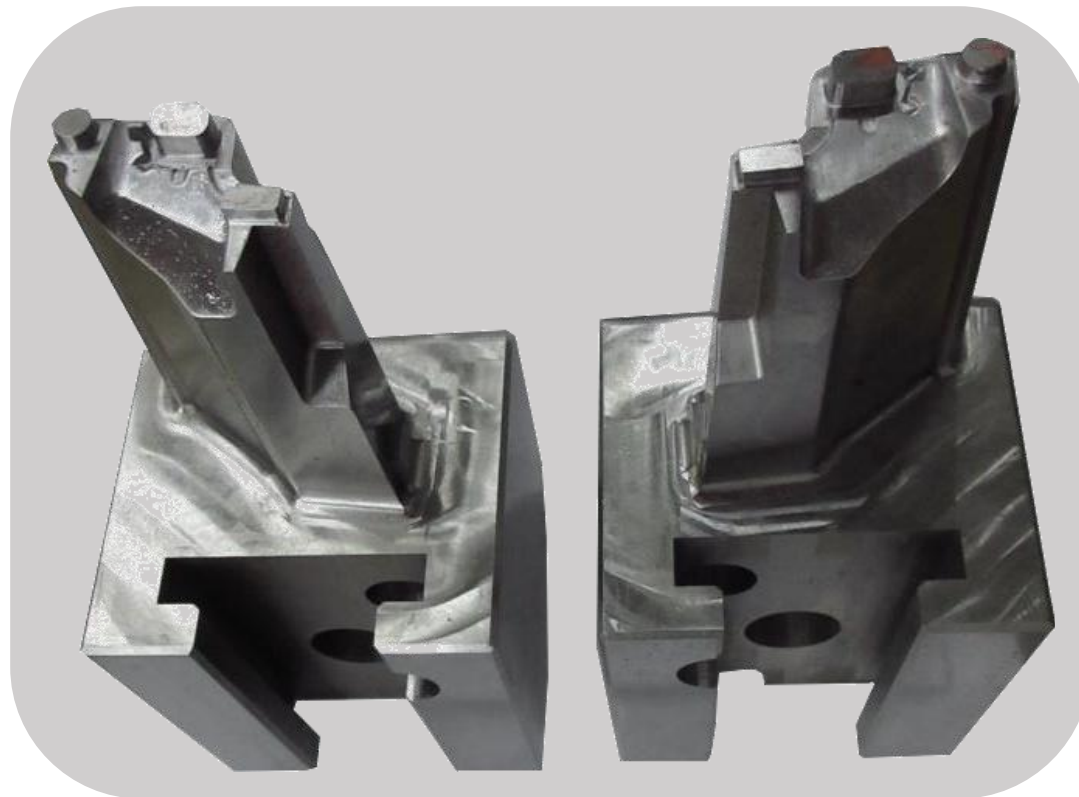
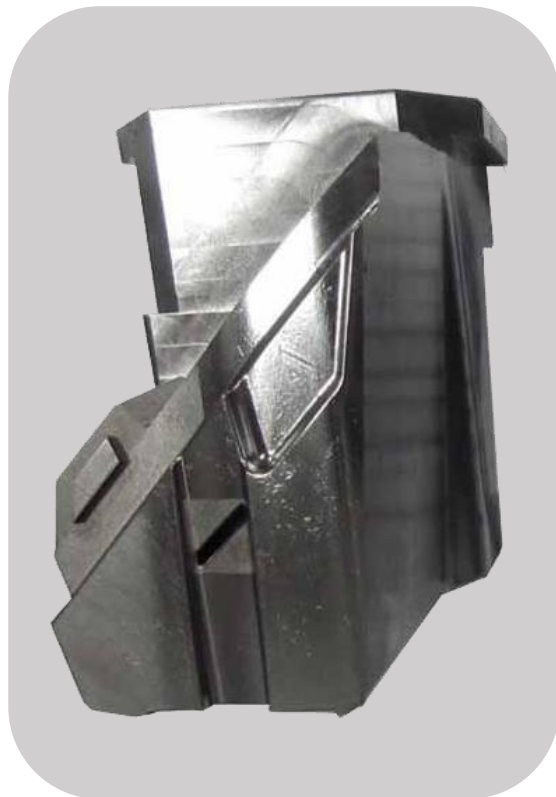

●Sliders or Cams

We make custom mold components, especially those parts that need CNC, EDM, WC processing.



Our Products

What We Can Do



Five-Star

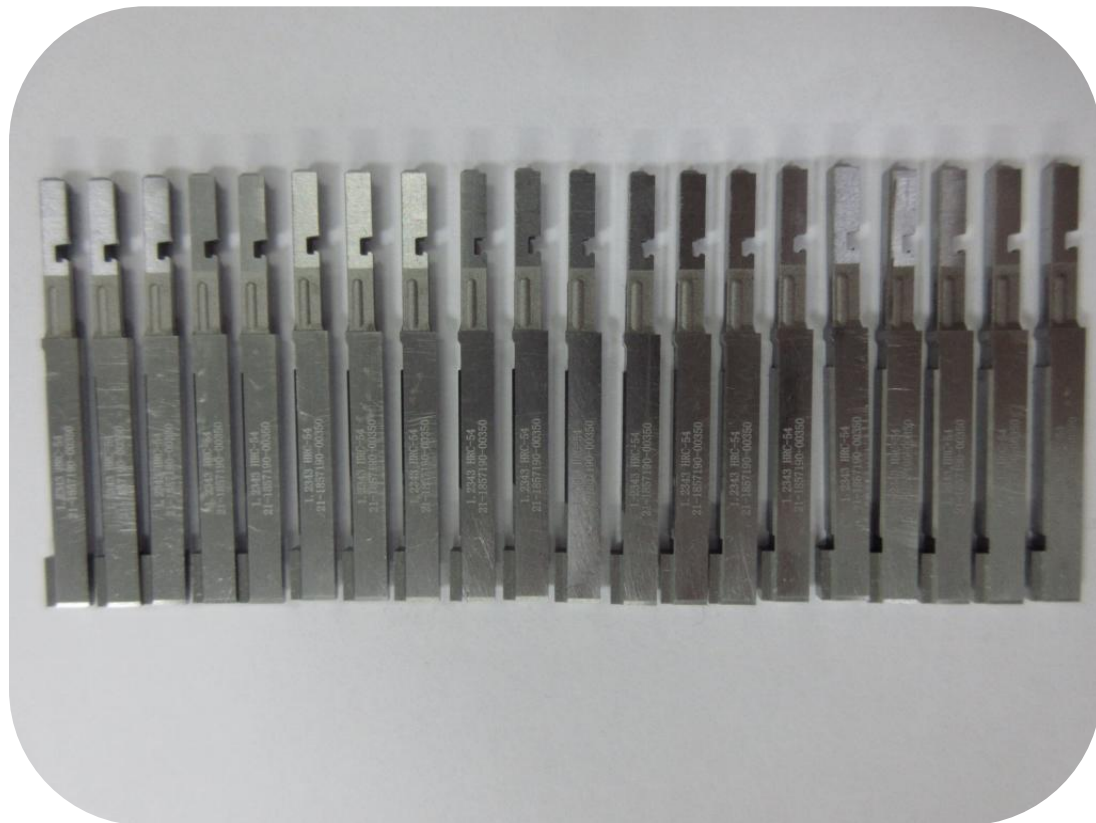

● High Tolerance Inserts

Tight tolerance parts: +/- 0.005mm



Our Products

What We Can Do



Five-Star



● Lifters / Cams



Our Products

What We Can Do



Five-Star



●Mould Inserts

Requires tolerance of around 0.005~0.015mm



Our Products

What We Can Do



Five-Star



●Round Parts

Tight tolerance parts: +/- 0.005mm



Our Products

What We Can Do



Five-Star

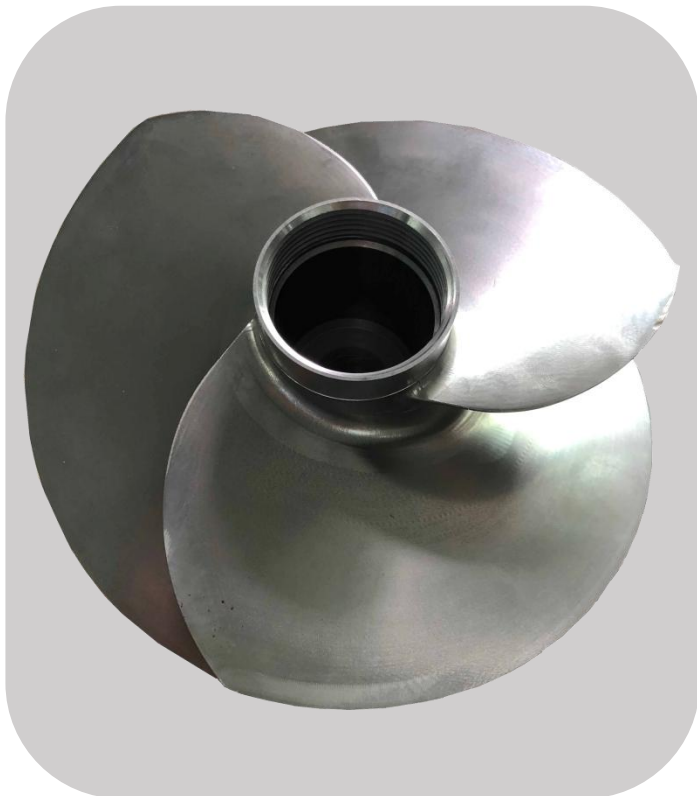

● Other Components

5 axis CNC manufacturing

Certification



Five-Star

编号: N^o 0060904



营业执照

(副本) (副本号:1-1)

统一社会信用代码 91441900MA4UH1QG8G

名称	东莞市星凯模具有限公司
类型	有限责任公司(自然人独资)
住所	东莞市大岭山镇矮岭冚村背底岭路193号
法定代表人	黄建德
注册资本	人民币伍拾万元
成立日期	2015年09月29日
营业期限	长期
经营范围	研发、产销: 模具、五金零件、塑胶制品、通用机械设备; 开发、销售: 企业管理软件; 货物进出口、技术进出口。(依法须经批准的项目, 经相关部门批准后方可开展经营活动。)



登记机关  2017年 8月 21日

请于每年6月30日前通过年度报告, 逾期将受到信用惩戒和处罚, 涉及: 登录企业信用信息公示系统, 或“东莞工商”微信公众号。

●FPC certificate in Dong Guan



Schmiedewerke Gröditz
GmbH • since 1779 • High-Grade Steel

Material Certify

NO.: BB1604066

TO: Five-Star Precision Components Ltd DATE: 2016-04-26

TEL: 0755-33653580 FAX: 0755-61675886

ADD: 东莞长安镇涌头社区宏丰路16号1楼一号铺

GRADE	SIZE	QTY	硬度 HB	牌号	炉号	ORDER DATE
W1.2344	63.7*83.3*202.7	1	≤229	FSP00421-P10/13-1Z	91860	Apr 25, 16
W1.2344	63.7*83.3*202.7	1	≤229	FSP00421-P10/13-1Y	91860	Apr 25, 16
W1.2344	85*94.38*244	1	≤229	FSP00421-P10/13-2Z	91860	Apr 25, 16
W1.2344	85.7*95.1*244.7	1	≤229	FSP00421-P10/13-2Y	91860	Apr 25, 16

主要成份%	C	Si	Mn	P	S	Cr	Mo	V
	0.38~0.42	0.80~1.20	0.30~0.50	≤0.025	≤0.005	4.80~5.50	1.20~1.50	0.90~1.10

TEL: 0755-27430610
FAX: 0755-27430609

We hereby certify that the above material are from Schmiedewerke Gröditz GmbH in Germany. We are only responsible for the above sizes and their products. Photocopy of this certificate is invalid.

 YUDING MOULSTEEL CO., LTD.

●Steel certificate (Groditz or S+B)

S+B 2005092

SCHMOLZ+BICKENBACH
Providing special steel solutions

Cert. ID: 813002095 -160300352
Invoice#:
Date: 2016/3/5
Issued by: 10-101 Page: Page 1

Customer: Five-Star Precision Components limited
Address: PO: PC160300004
Remarks:

TRANSCRIPT MATERIAL CERTIFICATE

S + B Grade	Description	Size(mm)			Qty	Model No.
		Thick(Dia)	Width	Length (PCS)		
Formdur 2711	Flat	38.00	53.00	445.00	1	FSP00400-101
Formdur 2711	Flat	38.00	53.00	445.00	1	FSP00400-402
Formdur 2711	Flat	26.00	30.00	430.00	1	FSP00400-403
Formdur 2711	Flat	26.00	30.00	430.00	1	FSP00400-404

ASTM	Hardness	C	Cr	Mo	V	Ni
P20 Super	35-40HRC	0.55	1.30	0.50	0.10	1.7

FOLLOWING BLANK
This page of the certificate produced by Dongguan Schmolz+Bickenbach Co., Ltd.

版权所有, 不得翻印, 如有侵权, 欢迎举报。
All rights reserved, copying is invalid, welcome to inquiry.

版权所有, 不得翻印, 如有侵权, 欢迎举报。
All rights reserved, copying is invalid, welcome to inquiry.

DEUTSCHE ESSELSTEELWERKE
FINEL STEEL



Our Clients

Direct and Indirect Customers

Welcome to visit our website at :
www.fstooling.com or www.fstooling.net

Our Clients

Direct & Indirect Customers



Five-Star



AIRBUS



JABIL



KOLEKTOR

RHYTHMIA
medical



MAGNA



Customer Reference

Ask for Information Needed about us



Goizper Group

Address: C/Antigua, 420.577 Antzuola,
GIPUZKOA-SPAIN
Tell: 943 786 230
Attn: Mr. Aitor Uribe-Etxebarria
Email: auribe@moldelan.com

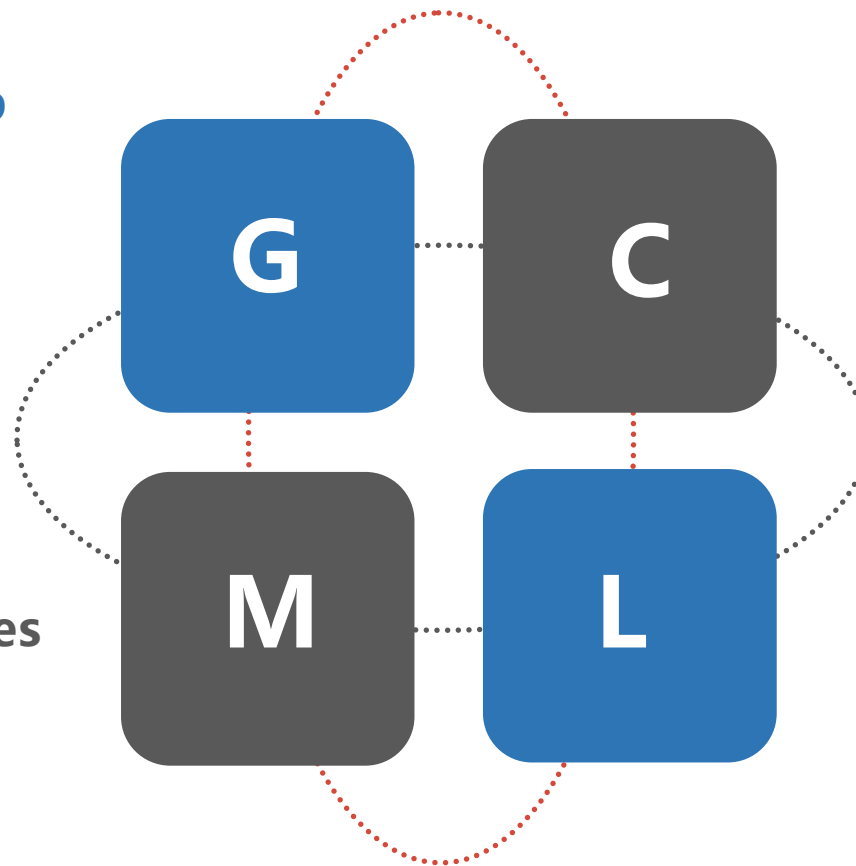

Caprock Mfg

Address: 2303 120th Street Lubbock,
TK 79423 USA
Tel: (806) 745-6454
Attn: Mr. Buster Lawson
Email: Buster@caprock-mfg.com

Micron Integrated Technologies

Address: 25 Sawyer Passway,
Fitchburg, MA 01420
Attn: Drew Santin
Ph: (978) 602-1430
Email: asantin@micronproducts.com

L-D Tool & Die

Address: 139 Iber Road Ottawa, ON K2S
1E7 Canada
Tel: (613) 591-1474
Attn: Mr. Lawrence Dickson
Email: ldickson@ldtool.com



1. Q: Do you have experience to build export precision metal components?
A: Yes, we do. Over 95% of our components are exported.
2. Q: How many employees do you have currently?
A: 23
3. Q: What 's the industrial percentage of your components ?
A: About 40% for automotive, 30% for medical, 30% for others.
4. Q: Can you make precision mould components ?
A: Yes. So far the best we can do is +/- 0.002mm. Normal tolerance will be +/- 0.005~0.015mm .
5. Q: How about the steel you usually use?
A: We use steel with good quality like P20, P20H, 718H, NAK80, 1.2311, 1.2378, 1.2344, 1.2343 ESR, 1.2767, H13, 8407, 420SS, S136, S-7, A2 etc. They are all from famous suppliers, such as Groditz, ASSAB, S+B, etc. Steel certificate and heat-treatment certificate will be provided when customer required.



6. Q: What do you need for quotation? And what kind of software do you use?

A: We need 2D & 3D components files , components specifications and BOM list.

We mainly use UG. But it is OK for us to read the files of CATIA , PRO-E and Solidworks, etc.



7. Q: Why can you do low-cost?

A: Focus and experience make high efficiency. Then it results in low cost.

8. Q: How about the lead time for components manufacturing?

A: Usually 1 to 3 weeks after received orders . For urgent projects, we can do 24 hours delivery as long as we can work it out.



Five-Star

Contact us

Five-Star Precision Components Limited (Components Manufacturing Shop)

Add:No.11, Yincheng 3 Road, Chang' an Town,
Dongguan City, Guangdong Province
523833 P.R. China

Tel: +86 769 8976 2586

Fax: +86 769 2720 0806

Web: www.fstooling.com

Email: sales@fstooling.net

Five-Star Tooling Limited (Mold Shop)

Add:Unit B, 1F&2F, Building 26, C Division, Shangcun
Liantang Industrial District, Gongming, Shenzhen,
Guangdong 518106, P.R. China

Tel: +86 755 3365 3580

Fax: +86 755 6167 5886

Web: www.fstooling.com

Email: sales@fstooling.net